

# AVERY DENNISON MARKETING SPECIFICATION

## HISTORY

REV.	DATE	DESCRIPTION
A	5/22/19	INITIAL RELEASE

THE SUBJECT MATTER DISCLOSED HEREIN EMBODIES PROPRIETARY INFORMATION WHICH IS THE CONFIDENTIAL PROPERTY OF THE AVERY DENNISON CO. NONE OF WHICH SHALL BE COPIED, REPRODUCED, DISCLOSED TO OTHERS, PUBLISHED OR USED IN WHOLE OR IN PART, FOR ANY PURPOSE OTHER THAN THAT FOR WHICH IT IS BEING MADE AVAILABLE WITHOUT THE EXPRESS ADVANCE WRITTEN PERMISSION OF A DULY AUTHORIZED AGENT OF THE COMPANY. THIS DOCUMENT IS THE PROPERTY OF THE AVERY DENNISON CO. AND IS TO BE RETURNED TO THE COMPANY ON DEMAND.

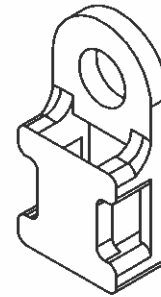
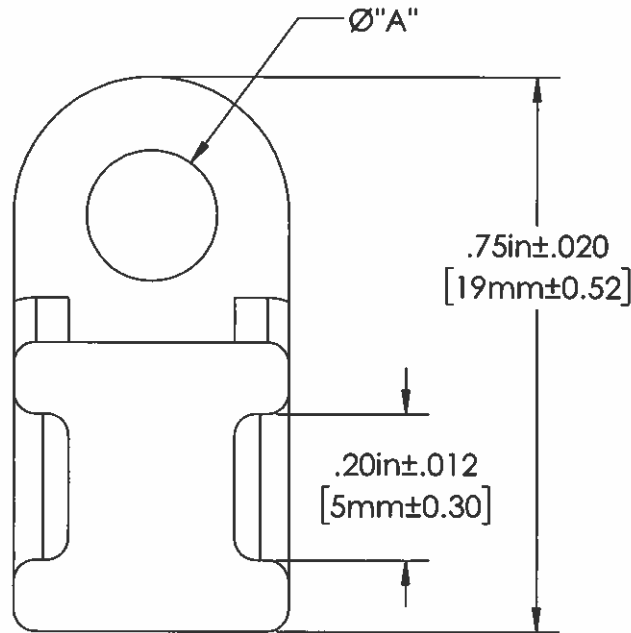

SCALE = 2:1

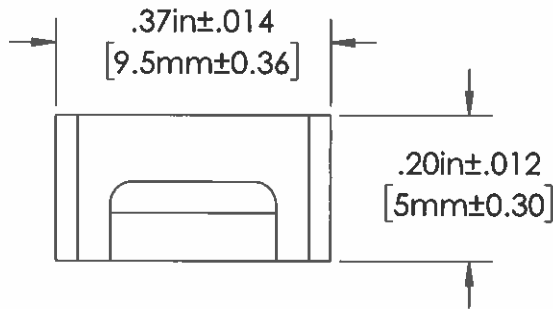

SCALE = 4:1

FLAMMABILITY RATING	UL 94V-2		
OPERATING TEMP	-40°C/(-40°F) TO 85°C(185°F)		
MIN. INSTALLATION TEMP	0°C/(32°F)		
MOUNTING	SCREW MOUNTING		
WEIGHT	.012gm/ (.34oz)	STOCK NO.	DIA "A"
PACKAGING	100/BAG, 1000/BOX, 5000/CARTON	10027-2	.169in±.012 / 4.3±.3mm
		10028-2	.203in±.012 / 5.2±.3mm
			SCREW SIZE
			#8 / M4
			#10 / M5

### APPROVALS:

ENG. APPR. *Bert Uschold* 5/22/19  
 Q.A. APPR. *Rich Estano* 5/22/19



FASTENER DIVISION  
 FITCHBURG, MA 01420 U.S.A.  
 TEL. 1-800-225-5913  
 FAX. 978-353-8157

### SPECIFIED TOLERANCES ARE:

.XX ± .03 INCHES    .X ± .7 mm  
 .XXX ± .010 INCHES    .XX ± .25 mm  
 ANGULAR: ± 2°

MATERIAL  
 NYLON 6/6  
 COLOR  
 NATURAL

DESCRIPTION  
 ANCHOR BASE CABLE TIE

PART NO.  
 10027-2 / 10028-2

REV.  
**A**